

**ISOLATOR SUBMITTAL
 RESTRAINED SPRING, 1" DEFLECTION**

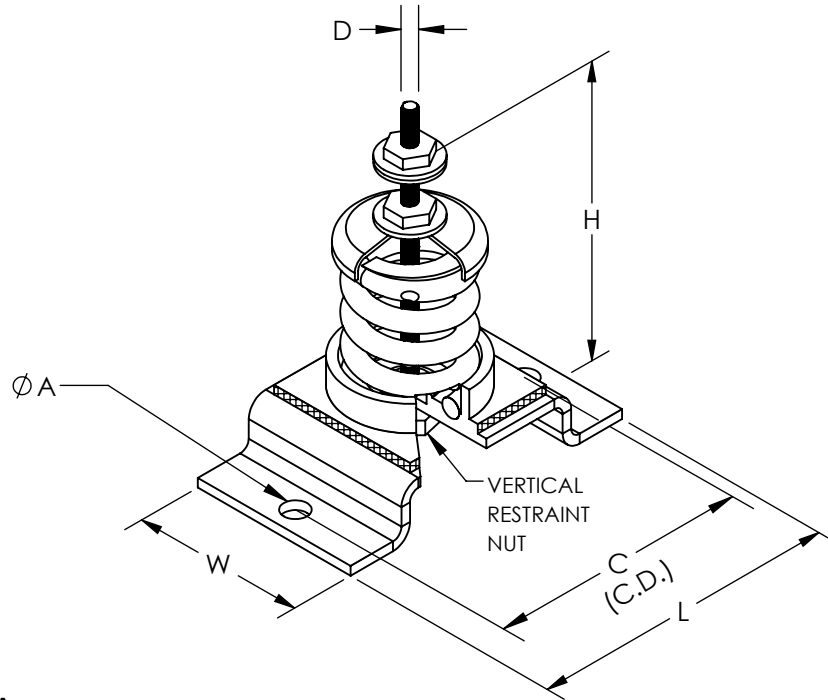

DIMENSIONAL DATA

SIZE	L	W	C	A	H	D
1-50/3500	8.00	4.50	6.50	0.69	9.00	0.63

MODEL		SPRING COIL					
		COLOR		FREE HT.	O.D.	RATED (LBS)	
TYPE	SIZE	OUTER	INNER			LOAD	DEFL.
FRS	1-50	BEIGE		4.20	3.00	50	1.00
FRS	1-100	CHROME		4.20	3.00	100	1.00
FRS	1-250	BLUE		4.20	3.00	250	1.79
FRS	1-450	GREEN		4.20	3.00	450	1.54
FRS	1-625	BLACK		4.20	3.00	625	1.44
FRS	1-800	GRAY		4.20	3.00	800	1.31
FRS	1-1000	RED		4.20	3.00	1000	1.15
FRS	1-1250	BROWN		4.20	3.00	1250	1.09
FRS	1-1700	ORANGE		4.20	3.00	1700	0.95
FRS	1-2200	ORANGE	GRAY	4.20	3.00	2200	1.00
FRS	1-2465	BLUE		4.20	3.00	2465	1.00
FRS	1-2865	BLUE	GRAY	4.20	3.00	2865	1.00
FRS	1-3500	BLUE	BROWN	4.20	3.00	3500	1.00

NOTES:

1. VERTICALLY AND LATERALLY RESTRAINED SPRING ISOLATOR.
2. REPLACEABLE NEOPRENE SNUBBER
3. MINIMUM OVERLOAD OF 50%
4. POWDER COATED SPRING ELEMENT, BRACKET IS HOT DIPPED GALVANIZED.
5. FOR ADEQUATE ANCHOR SIZING, TORQUE, AND BASEPLATE REQUIREMENTS, VISIT kineticsnoise.com/frs/restrained-spring-isolator

ALL DIMENSIONS ARE IN INCHES